

Eclipse Ratiomatic Burners

Model 1000 RM
For Serial Numbers 95-5500 & Above

Version 1

Parameter	Specification	
Input vs. Chamber Pressure	12,500,000 BTU/hr @ -5.0" w.c.	3664 kW @ -12.5 mbar
	11,600,000 BTU/hr @ -3.0" w.c.	3400 kW @ -7.5 mbar
	10,500,000 BTU/hr @ -1.0" w.c.	3107 kW @ -2.5 mbar
	10,000,000 BTU/hr @ 0.0" w.c.	2931 kW @ 0.0 mbar
	9,400,000 BTU/hr @ +1.0" w.c.	2755 kW @ +2.5 mbar
	8,800,000 BTU/hr @ +2.0" w.c.	2579 kW @ +5.0 mbar
	Input may be increased by 20% if sufficient secondary air is available to complete combustion.	
Maximum Input	100,000 BTU/hr (29.3 kW) with neutral chamber. Will be slightly higher with negative chamber pressure.	
Turndown	100:1 with neutral chamber pressure	
Configurations	Burner Configuration	Maximum Chamber Temperature
	Burner with alloy tube	1500°F (816°C)
	Burner with refractory block	1800°F (982°C)
Maximums shown are for average installations. Depending on conditions, higher temperatures can be obtained. Contact Eclipse for details.		
Fuel	Standard nozzle burns natural gas, propane, propane/air mixes without changing internals. Contact Eclipse for other fuels.	
Gas Inlet Pressure at the proportionator inlet	Minimum: 14" w.c. (35 mbar) natural gas, .65 s.g. Maximum: 2 psig (138 mbar) natural gas, .65 s.g.	
Pilot Gas Pressure at the pilot cock inlet	Minimum: 6" w.c. (15 mbar) natural gas, .65 s.g.	
High Fire Flame Length	124" (3.15 m) Measured from the end of the firing tube, firing parallel to air flow with neutral chamber pressure. When firing perpendicular to air flow, flame length will be shorter. Contact Eclipse for details.	
Piloting	Integral spark-ignited pilot; ignition plug included	
Flame Monitoring	By UV scanner only. Scanners & mounting kits are available from Eclipse.	
Control Motor Requirements	90° travel with full stroke timing of 15 seconds or longer. Ovens with high chamber drafts or backpressures may require less than a full 90° stroke. In these cases, use adjustable stroke motors or motors equipped with travelling limiting auxiliary switches.	
Emissions	Ratiomatics produce low NO _x , CO and aldehydes. Emissions performance depends not only on the burner, but also factors such as chamber temperature, chamber design, and heat loading. For estimates of Ratiomatic performance in your application, call Eclipse.	
Packaging Options	IRI or NFPA type valve trains, and UL recognized valve packages available.	



CAUTION:

It is dangerous to use any fuel burning equipment unless it is equipped with suitable flame sensing devices and automatic fuel shut-off valves. Eclipse can supply such equipment or information on alternate sources.

Dimensions

Dimensions are subject to change without notice. Contact Eclipse for certified prints prior to fabrication or installation.

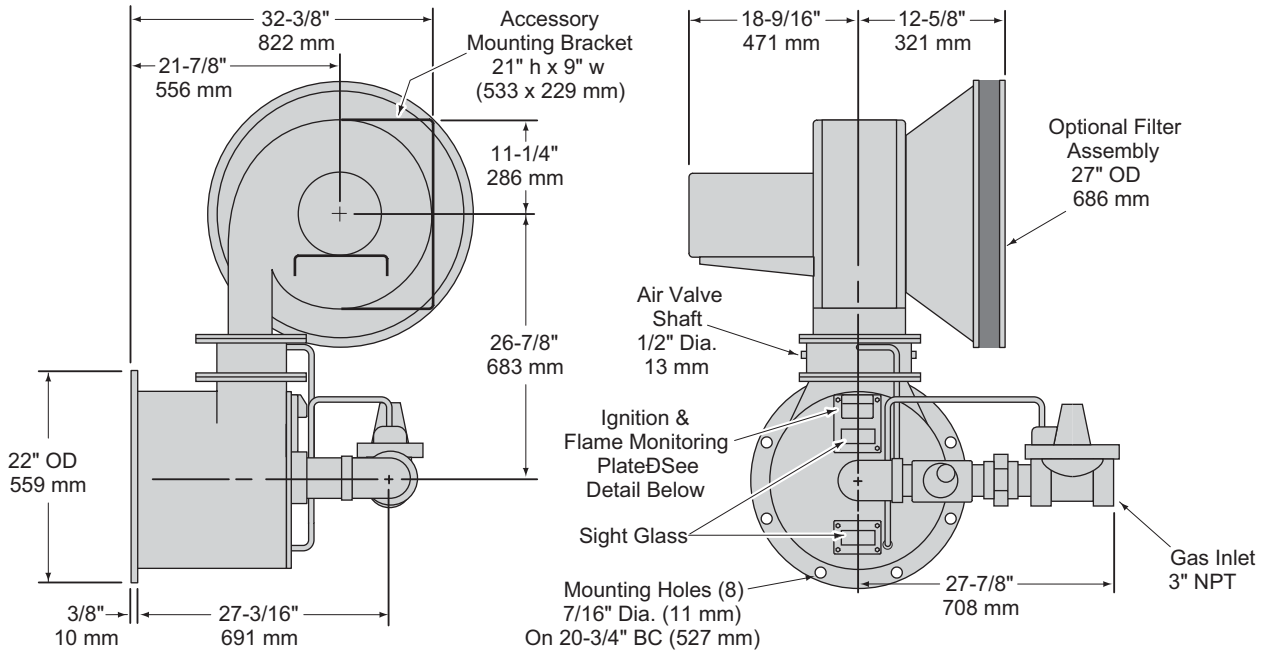

Alloy Tube Assembly – #110265

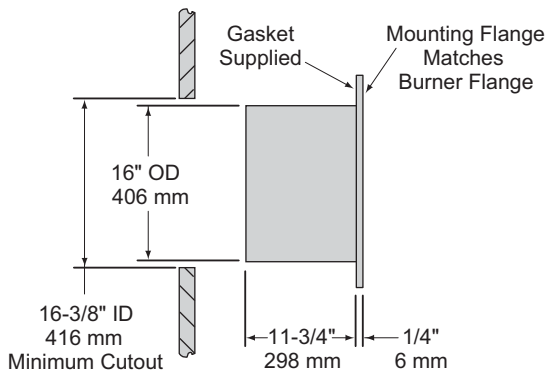

Block & Holder Assembly – #187296-61

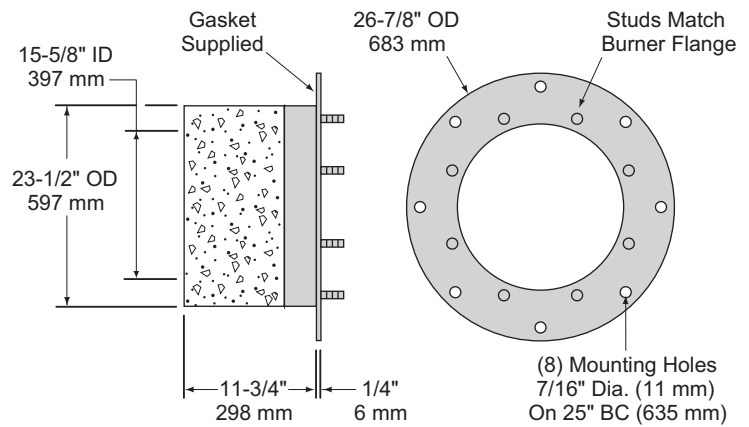

Item	Description	Part No.
1000 RM Burner Assembly	w/Alloy Tube; Left Hand Blower (shown)	110411
	w/Alloy Tube; Right Hand Blower (motor opposite side)	110401
	w/Block & Holder; Left Hand Blower (shown)	110441
	w/Block & Holder; Right Hand Blower (motor opposite side)	110431
Air Filter Assembly	Optional	110280
Replacement Filter Element	-	15608
Spark Plug ¹	For burner with tube or block	150000-5
Blower Motor ¹	7.55 hp, 230/460/3/60 TEFC, 3600 RPM	11215
Proportionator ¹	Eclipse ES 369, 3"	10316
Pilot Cock ¹	Eclipse lever handle, 1/4"	12659
Gas Adjusting Butterfly ¹	Eclipse 112 BV, 3"	500993

¹ Included with burner assembly.

Block & Holder and Alloy Tubes are interchangeable in the field.

Flame Monitoring Plate Detail

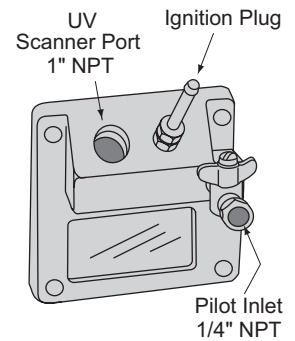



Offered By:

Power Equipment Company
2011 Williamsburg Road
Richmond, Virginia 23231
Phone (804) 236-3800
Fax (804) 236-3882

www.peconet.com